

UNIVERSITY OF CALIFORNIA, SAN DIEGO

R

U

W

U

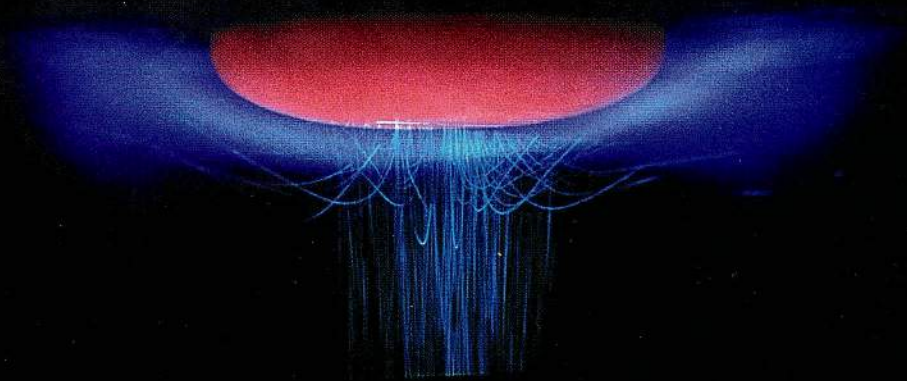

Center  
for  
Energy  
&  
Combustion  
Research

Center  
for  
Energy  
&  
Combustion  
Research

3

University of California, San Diego

4

Center for Energy and Combustion Research

6

Graduate Study

7

Global Participation & Affiliated Faculty

24

Living in San Diego

RECEIVED

*UCSD is  
recognized as one of the truly*



# innovative institutions for science and technology in the world

## The University of California, San Diego

The rise of the University of California, San Diego (UCSD) to national prominence among universities in the United States has been truly remarkable. UCSD was established in 1960 by the Regents of the University of California as an outgrowth of the Scripps Institution of Oceanography (SIO) and is recognized as one of the truly innovative institutions for science and technology in the world, ranking tenth nationwide in both mechanical and aeronautical engineering, according to a recent survey by the National Research Council. In barely 30 years, UCSD has accomplished what other universities have failed to do in more than 100 years.

As proof of its standing, UCSD's faculty includes:

- seven Nobel Laureates
- three winners of the California Scientist-of-the-Year award
- six recipients of the National Medal of Science
- fifty-four members of the National Academy of Sciences
- eleven members of the National Academy of Engineering
- seven members of the International Academy of Astronautics including former NASA astronaut Sally Ride

The collection of talent already has paid off in federal funding on par with the top academic institutions in the country. Other outstanding features:

- UCSD ranks fourth among all U.S. universities in federal funds received for research and development over the past five years
- UCSD ranks third in funds received from the National Science Foundation

The University of California, San Diego is located in La Jolla, a coastal town near the northern limits of San Diego. The thousand-acre campus spreads from the seashore, home of Scripps Institution of Oceanography, across the adjacent Torrey Pines Mesa, high above the Pacific Ocean. The campus has grown steadily since it opened to undergraduates in 1964 and now has a faculty of over 1,000, an undergraduate enrollment of about 15,000, and a graduate enrollment of about 2,000.

An atmosphere of intellectual stimulation pervades this campus. Excellence in research always has been a goal of the institution. There has been recent growth in engineering and applied science that has emphasized cooperation with industry, government, and other research and educational institutions in fostering zealous research to address scientific, technological and societal problems. The *Center for Energy and Combustion Research* thus enjoys a remarkably favorable environment.



Aerial view of the University of California, San Diego.

## CECR addresses important

The UCSD Energy Center commenced operation informally during the fall of 1973 under the impetus of Professor Stanford S. Penner. Formally designated as an organized research unit on July 1, 1974, the Energy Center has addressed applica-

### Center for Energy and Combustion Research (CECR)

tion foci that vary in response to societal, university and student needs. This center was given its new name, *Center for Energy and Combustion Research (CECR)*, in 1986 to

underscore the close link between energy and combustion research. Professor Forman A. Williams, an internationally renowned combustion specialist, succeeded S.S. Penner as director in 1990. More than 70 percent of the current funding of the center is related to combustion research in some way.

Since its origins, the center has focused on basic problems in finding new sources of energy and the social, environmental, economic and political consequences of energy consumption, including combustion. Studies range from investigations into the fundamental nature of energy and combustion to practical applications in energy conservation and production, as well as pollution control. Today, under the direction of Professor Williams, *CECR* exists to further basic scientific understanding and wide-ranging applications of energy resources, including both fossil and

non-fossil fuels. There are investigations related to the safe exploitation of nuclear energy and to reduction of emissions of greenhouse gases in combustion processes. Studies are in progress concerning the minimization of emissions of soot and oxides of nitrogen from flames of both gaseous and liquid fuels, including sprays in Diesel and gas-turbine engines, as well as systems employing natural gas and coal. Researchers also pursue investigations of the stability of combustion chambers for propulsion applications, for example, applying the strong *CECR* expertise in fluid mechanics, reacting flows and turbulent combustion. In addition, there are fundamental studies in microgravity combustion science, involving droplet-burning experiments in Spacelab and in other NASA facilities.

*CECR* brings together faculty, researchers and students from across a broad range of disciplines: applied mathematics, physics, chemistry, oceanography, meteorology and economics, as well as mechanical, aerospace, civil and chemical engineering. Experimental, analytical and computational research methods are used to study chemical and physical aspects of combustion phenomena. Application of all three of these basic methods to achieve definitive advances is a particular goal of the center. Examples of ongoing research are projects in mitigation of combustion-generated air pollution, propellant combustion and combustion instability,

# *fundamental, scientific, technological and societal problems*



CECR is located in the new Engineering Building.

incineration of toxic and non-toxic waste materials, as well as finding replacements for halogen-containing fire suppressants to reduce ozone depletion.

*CECR* research encompasses significant efforts in mathematical theory, numerical analysis and computation, laboratory experimentation and natural observation. On the applications side, *CECR* addresses important societal problems such as the efficient use and production of energy, the design and propulsion of airborne and waterborne vehicles, water quality and reclamation technology, aspects of materials processing, including self-propagating high-temperature synthesis, as well as practical uses of catalysis. *CECR* emphasizes fundamental research in its disciplines, application of basic knowledge to address the needs of society and education of students through their involvement in the research and its applications. The value of research grants currently in effect exceeds one million dollars annually, with funding from the National Aeronautics and Space Administration (NASA), various branches of the Department of Defense (DOD), the Department of Energy (DOE) and the National Science Foundation (NSF).

## ***Energy Research***

Important studies have included energy conservation for home and industrial use, evaluations of advanced fossil-fuel technologies such as coal gasification and liquefaction, oil recovery from heavy oil sources, tar sands and oil shale, developments of advanced fuel cells and investigations of geothermal and renewable energy sources.

Recent investigations have dealt with model developments and environmental-impact assessments for municipal-waste incinerators, studies on diagnostics of pollutant outputs, aspects of the designs of passively safe nuclear reactors, such as degradation of graphite by reactions with low concentrations of water or air and prospects for the utilization of fuel-cell technologies.

## ***Combustion Research***

Current fundamental studies in combustion involve theory and experimentation on structures of hydrocarbon-air premixed flames and diffusion flames, including experimental measurements, supercomputer computations with full chemical-kinetic mechanisms and development of asymptotic methods for reduced chemical kinetics.

Applications relate to aerospace-plane propulsion, to efficient power production by fossil fuels and to minimization of pollutant emissions from combustion chambers. The research is addressing problems of combustion in Diesel engines, in gas turbines and in rocket propulsion, including emissions of oxides of nitrogen from flames, combustion instabilities in liquid-propellant rocket motors and efficient and clean combustion of fuel sprays.

## ***Research Facilities***

The *CECR* research facilities include three gas-chromatographic systems for measurements of concentrations of stable chemical species, a laser-Doppler velocimeter for velocity measurements in reacting flows, an argon-ion laser system for measurement of particle sizes and number densities by Mie scattering and a phase-Doppler particle analyzer for measurements of fuel sprays. Laser spectroscopic capabilities include Rayleigh, Raman and fluorescence spectroscopy using pulsed lasers with advanced detection systems for both one-dimensional and two-dimensional imaging. In addition, there is a laminar coflow diffusion-flame apparatus and a number of counterflow combustion systems for measurement of diffusion-flame, premixed-flame, fuel-spray and catalytic-combustion processes. Computer systems for computation of flame structures with full chemistry and for extraction of histories of droplet and flame diameters from video or photographic records are available. Droplet-trajectory and droplet-combustion facilities with photographic recording are in place, and a turbulent-jet flame apparatus is under construction, as is a solid-propellant combustion facility and a high-pressure combustion chamber.

# A program of study is selected to meet the needs and goals of each student

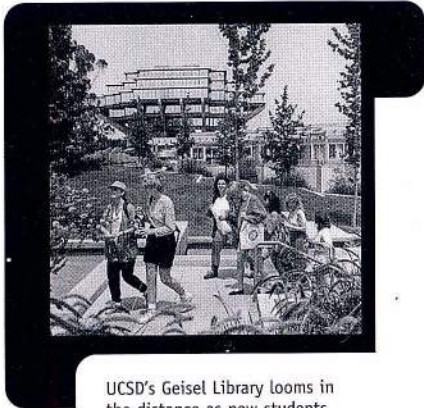

UCSD's Geisel Library looms in the distance as new students cross campus.

## Graduate Study

CECR students generally enroll in an engineering department in which the graduate program has no specific course requirements. A program of study is selected by each student, with his or her faculty adviser, to meet the needs and goals of the student and to account for the strengths and deficiencies of prior education.

Graduate study consists of both courses and research. Students are encouraged to pursue research along with their classes. Research topics are selected in consultation with the faculty adviser.

## Financial Assistance

Financial aid is available in the form of fellowships, teaching assistantships and research assistantships. CECR attempts to support all full-time graduate students, especially at the PhD level. Award of financial support is competitive, and stipends range from \$5,000 to a maximum of \$20,000 for the academic year, plus tuition and fees.

The following list of engineering graduate courses is typical of those selected by CECR students. Courses in mathematics, chemistry, physics, biology and other such topics are also accepted and encouraged as part of the graduate course curriculum. UCSD operates on a quarter system, and A-B-C designations indicate a sequence of successive quarters in a given area.

- 210A-B-C Fluid Mechanics
- 211 Introduction to Combustion
- 212 Introductory Compressible Flow
- 213 Mechanics of Propulsion
- 214A-B Introduction to Turbulence and Turbulent Mixing
- 215 Hydrodynamic Stability
- 220A Physics of Gases
- 220B Physical Gas Dynamics
- 220C Nonequilibrium Gas Dynamics
- 221A-B-C Heat and Mass Transfer
- 222A-B-C Advanced Fluid Mechanics
- 223 Computational Fluid Dynamics
- 226A-B-C Advanced Engineering Physics
- 290A-B Numerical Methods in Engineering Science
- 294A-B-C Methods in Applied Mechanics
- 296 Independent Study
- 298 Directed Group Study
- 299 Graduate Research

Application forms for admission and for financial support may be obtained from:

University of California, San Diego  
Department of AMES  
Student Affairs Office, 0413  
9500 Gilman Drive  
La Jolla, CA 92093-0413  
(619) 534-5266

Information about a particular research area is best obtained by writing directly to individual faculty members at:

University of California, San Diego  
Center for Energy and  
Combustion Research, 0411  
9500 Gilman Drive  
La Jolla, CA 92093-0411

For a UCSD *General Catalog*, please send \$5.75 (payable to the UC Regents) to:

University of California, San Diego  
Publications Office, 0941  
9500 Gilman Drive  
La Jolla, CA 92093-0941

WWW Address:  
<http://www-ames.ucsd.edu/research-units/cecr/welcome.html>

## GLOBAL PARTICIPATION

Faculty and staff members associated with *CECR* are involved in studies of energy policy and combustion issues at local, state, national and international levels. The editorial offices for *Energy—The International Journal* (published by Pergamon Press in London, England, since 1975) remain housed at *CECR*. In addition, *CECR* participants interact extensively abroad on energy and combustion issues. There is continuing joint research with investigators at Cambridge University, England, RWTH Aachen, Germany, Université de Provence, Marseilles, France, University of Madrid, Spain, and elsewhere. Renowned scientists from throughout the United States and abroad, specializing in energy and combustion research, regularly visit UCSD and participate in *CECR* programs through formal lectures, research activities and informal discussions. Recent global participants include:

### Distinguished Visitors

Gerhad Adomeit	RWTH Aachen, Aachen, Germany
Demetrio Bastos-Netto	Instituto Nacional de Pesquisas Espaciais, Cachoeira Paulista, Brasil
Bob Bilger	University of Sydney, Sydney, Australia
Ken Bray	Cambridge University, Cambridge, England
Tai-yue Cao	Changsha Institute of Technology, Changsha, China
Michel Champion	ENSMa, Poitiers, France
Harsha Chelliah	University of Virginia, Charlottesville, Virginia
Michal Cialkowski	Institute for Heat Engineering and Combustion, Engines of Mosina, Poland
Paul Clavin	Université Aix Marseilles, Marseilles, France
Eli Dabora	University of Connecticut, Storrs, Connecticut
Pedro Garcia-Ybarra	Universidad Nacional de Educacion a Distancia, Madrid, Spain
Toshisuke Hirano	University of Tokyo, Tokyo, Japan
Johan Hustad	Norwegian Institute of Technology, Trondheim, Norway
John Lee	McGill University, Montreal, Canada
Yi-min Li	Beijing University of Aeronautics and Astronautics, Beijing, China
Amable Liñán	Ciudad Universitaria, Madrid, Spain
Tai-kang Liu	Chung Shan Institute of Science and Technology, Taiwan, China
Akira Matsushita	Japanese Patent Office, Tokyo, Japan
Tohru Mitani	Kakuda Research Center, National Aerospace Laboratory, Japan
Takashi Niioka	Tohoku University, Sendai, Japan
Tony Oppenheim	University of California, Berkeley, California
Norbert Peters	RWTH Aachen, Aachen, Germany
Josef Rom	Technion-Israel Institute of Technology, Haifa, Israel
Junichi Sato	IHI Research Institute, Tokyo, Japan
Mitch Smooke	Yale University, New Haven, Connecticut
César Treviño	Facultad de Ingeniería, UNAM, Mexico City, Mexico
Shunichi Tsugé	University of Tsukuba, Tsukuba, Japan
Pierre Van Tiggelen	Universite Catholique de Louvain, Louvain-la-Neuve, Belgium
Carlos Vasques-Espi	Universidad Politecnica, Madrid, Spain
Sun Yi	Energy Conservation Technology Center, Harbin, China

Forman A. Williams, Director  
Robert J. Cattolica, Associate Director  
K. Seshadri, Associate Director

David J. Benson

Alvin S. Gordon

Jong Soo Kim

Juan C. Lasheras

Shui-Chi Li

Paul A. Libby

Kurt O'Ferrall Lund

Marc A. Meyers

David R. Miller

Vitali F. Nesterenko

Keiko Nomura

Stanford S. Penner

Sutanu Sarkar

Massoud Simnad



## DAVID J. BENSON

PhD in Mechanical Engineering

Associate Professor of Mechanical Engineering



Professor Benson received his PhD in mechanical engineering from the University of Michigan in 1983. Prior to joining UCSD's engineering faculty in 1987, he was a research engineer for University of California's Lawrence Livermore National Laboratory and a principal analyst for Mechanical Dynamics Incorporated, where he was involved in consulting and software development. Professor Benson's research expertise lies in computational methods for nonlinear, large deformation problems in solid

mechanics. His current research focus encompasses the micromechanics of detonation; the effect of damage in energetic materials; multi-material Eulerian finite-element formulations; arbitrary Lagrangian-Eulerian methods; and shock synthesis and reaction of advanced materials. Professor Benson is a member of the American Society of Mechanical Engineers (ASME) and serves on the ASME Committee on Computing in Applied Mechanics.

### Representative Recent Publications

1. D.J. Benson, "Numerical Simulations of Dynamic Compaction," *Proceedings of the Net Shape Processing of Powder Materials Symposium*, ASME International Mechanical Engineering Congress and Exposition, San Francisco, Nov. 12-17, 1995.

2. D.J. Benson, "Micromechanical Analyses of the Shock Processing of Ductile Materials," *Proceedings of the Symposium on Computational Methods in Micromechanics*, ASME International Mechanical Engineering Congress and Exposition, San Francisco, Nov. 12-17, 1995.

3. D.J. Benson, W. Tong and G. Ravichandran, "Particle-Level Modeling of Dynamic Compaction of Ti-SiC Powders," *Modeling and Simulations In Materials Science and Engineering*, Vol. 3, pp. 771-776, 1995.

4. D.J. Benson, "The Numerical Simulation of the Dynamic Compaction of Powders," *High Pressure Shock Compression of Solids IV, Response of Highly Porous Solids to Shock Loading*, edited by L. Davison, Y. Horie, M. Shahinpoor, Springer-Verlag, 1996.



HMX power micrograph.

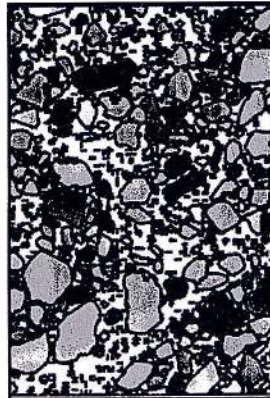

FEM model via image processing.

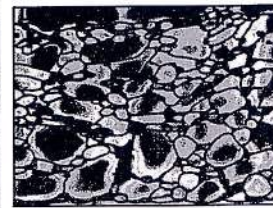

Predicted temperature after shock compression.

## ROBERT J. CATTOLICA

PhD in Engineering Physics

Professor of Engineering Physics and Associate Director, CECR

Professor Cattolica received his PhD in engineering physics from Berkeley in 1973 and, after performing research and serving on the scientific and technical staff of the Combustion Research Facility of Sandia National Laboratories, joined UCSD's engineering department in 1990. His research interests lie in experimental methods in reactive flows: combustion and high-speed gas dynamics with a specific emphasis on optical-diagnostics techniques, such as laser and electron-beam fluorescence spectroscopy, absorption spectroscopy, Raleigh scattering and spectroscopic imaging techniques. His current research involves the development of spectroscopic diagnostics for aerodynamics associated with planetary entry and aero-

braking. He also addresses specific research problems on the analysis of  $\text{CO}_2^+$  fluorescence for temperature and density measurements. He is also working on the development of models for the prediction of electron-beam propagation in  $\text{CO}_2^-$  investigating the development of electron-beam fluorescence from the  $A^2\Pi-X^2\Pi$  and  $B^2\Sigma-X^2\Pi$ ; transitions of  $\text{CO}_2^+$ ; rotational line-strengths of multi-pole transitions in linear molecules, and spectroscopic modeling of Renner-Teller bands in electron-beam fluorescence of  $\text{CO}_2^+$ . Additional research topics include diagnostics development for unsteady two-phase combustion processes, diode-laser spectroscopy for gas-phase measurements of concentration and temperature in coal-particle/methane combustion, optical techniques for particle sizing in reactive flows and laser-fluorescence imaging of two-phase opposed-jet flames.



### Representative Recent Publications

1. R. J. Cattolica, "Electron Beam Fluorescence Imaging for Hypersonic Research," *New Trends in Instrumentation for Hypersonic Research*, A. Boutier, ed., NATO ASI Series E: Applied Physics, Vol. 224, pp. 275-285, Kluwer Academic Publishers, Dordrecht, 1993.
2. C. Danker, R. Cattolica and W. Sellers, "Local Measurements of Temperature and Concentrations: A Review for Hypersonic Flows," *Theoretical and Experimental Methods in Hypersonic Flows*, NATO, AGARD-CP-514, pp. 12A1-12B10, Nueilly Sur Siene, France, 1993.
3. R. J. Cattolica and T. G. Mataga, "OH Rotational Temperature Measurements in Hypersonic Shock Waves," *Rarefied Gas Dynamics: Experimental Techniques*, Vol. 158, pp. 79-89, AIAA, Washington, D.C., 1994.
4. D.R. Farley and R. J. Cattolica, "Electron-Beam Fluorescence Measurements of Density and Rotational Temperature in a Simulated Martian Atmosphere," *Rarefied Gas Dynamics*, Vol. II, pp. 1425-1432, Oxford University Press, Oxford, 1995.

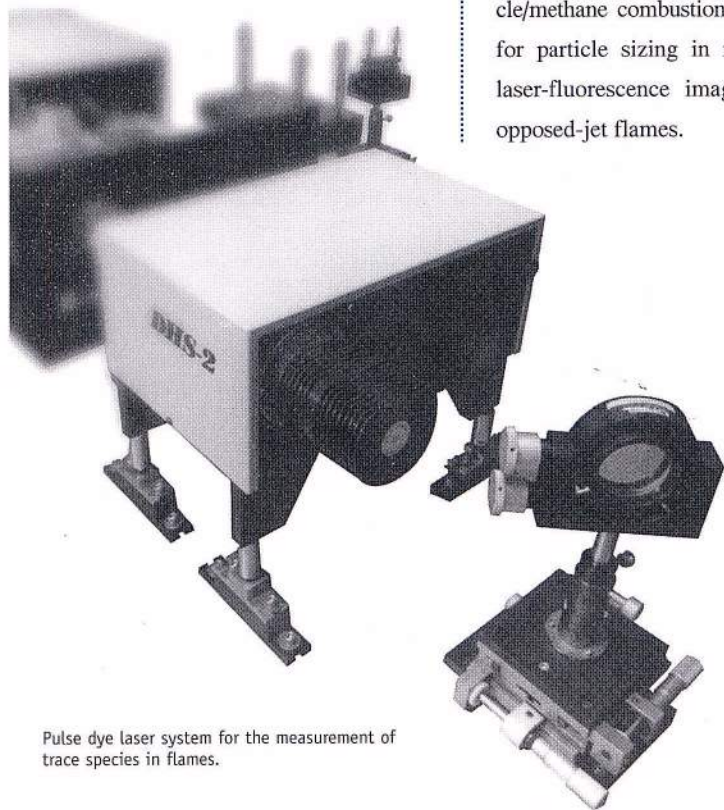

Pulse dye laser system for the measurement of trace species in flames.

## A.S. GORDON

PhD in Chemistry

Adjunct Professor of Engineering Chemistry

### Recent Representative Publications

1. K. Saito, A.S. Gordon, F.A. Williams and W.F. Stickle, "A Study of the Early History of Soot Formation in Various Hydrocarbon Diffusion Flames," *Combustion Science and Technology*, Vol. 80, pp. 103-119, 1992.
2. A.S. Gordon and T.C. Austin, "Alternative Fuels for Mobile Transport," *Progress in Energy and Combustion Science*, Vol. 18, pp. 493-511, 1992.
3. A.S. Gordon, S.C. Li, P.A. Libby and F.A. Williams, "Influence of Initial Velocity Distributions on the Height of Methane-Air Non-Premixed Flames," *Combustion Science and Technology*, Vol. 100, pp. 395-399, 1994.
4. S.C. Li, A.S. Gordon and F.A. Williams, "A Simplified Method for the Computation of Burke-Schumann Flames in Infinite Atmospheres," *Combustion Science and Technology*, Vol. 104, pp. 75-91, 1995.

1. J.S. Kim and F.A. Williams, "Structures of Flow and Mixture-Fraction Fields for Counterflow Diffusion Flames with Small Stoichiometric Mixture Fractions," *SIAM Journal on Applied Mathematics*, Vol. 53, pp. 1551-1566, 1993.
2. P. Clavin, J.S. Kim and F.A. Williams, "Turbulence-Induced Noise Effects on High-Frequency Combustion Instabilities," *Combustion Science and Technology*, Vol. 96, pp. 61-84, 1994.
3. J.S. Kim and F.A. Williams, "Contribution of Strained Diffusion Flames to Acoustic Pressure Response," *Combustion and Flame*, Vol. 98, pp. 279-299, 1994.
4. J.S. Kim, "Effects of Turbulence on Linear Acoustic Instability: Spatial Inhomogeneity," *Liquid Propellant Rocket Combustion Instability*, *Progress in Astronautics and Aeronautics*, Vol. 169 (Vigor Yang, ed.) pp. 431-454, AIAA, Washington, D.C., 1995.

After earning his PhD in physical chemistry from New York University, Professor Gordon was employed by the U.S. Navy in the China Lake facility, rising to the position of supervising physical chemist. During this period he also served as a scientific liaison officer in the Navy's London Office. Additionally, Professor Gordon spent an academic year in Princeton University. In 1976, he was appointed adjunct professor of engineering chemistry in the AMES department at UCSD—a position he still holds. From 1976-82, Professor Gordon served as a member of the California Air Resources

Board, and from 1980-94, he was a member of the Research Screening Committee of the California Air Resources Board. His interests lie in combustion phenomena, especially in mechanisms of chemical reactions, the structure of diffusion flames and formation of soot in hydrocarbon flames. His current research activities concern defining important factors for determining height of co-axial fuel-air diffusion flames, lifting molecular compounds from soot, graphite and diamond by shocks from laser bombardment and the combustion mechanisms of pool fires.

## JONG SOO KIM

PhD in Engineering Physics

Assistant Project Scientist

Jong Soo Kim received his PhD in engineering physics from UCSD in 1991, after finishing his BS and MS degrees from Seoul National University, Korea. He has been a member of the CECR research staff since 1992. His research interests focus on the fields of combustion and rocket propulsion with emphasis on asymptotic analyses of flame structure, extinction and stability. He is currently working on application of asymptotic

methods, which have been successfully used in combustion theory, to acoustic instability of liquid-propellant rocket engines, in order to identify the instability mechanisms and to understand influences of turbulence on acoustic instability. From this research, he was able to provide a physical explanation to the random surges of the acoustic pressure amplitude, observed inside combustion chambers of liquid-propellant rockets.

## JUAN C. LASHERAS

PhD in Mechanical and Aerospace Engineering

Professor of Fluid Mechanics

Professor Lasheras received a PhD from the Department of Mechanical and Aerospace Engineering at Princeton University in 1982. After a two-year period as a research engineer at the Koninklijke Shell Laboratorium-Amsterdam in The Netherlands, he joined the Department of Mechanical Engineering of the University of Southern California and then moved to the Department of Applied Mechanics and Engineering Sciences at the University of California, San Diego. His research interests include three-dimensional instabilities in free-shear flows, particle mechanics in

turbulent flows, particle sedimentation and suspension mechanisms and flame instabilities. Among his academic honors, Professor Lasheras received the 1995 Outstanding Teaching Award from the Department of AMES and the 1994 top Annual Teaching Award from the School of Engineering, and he has been awarded Professeur Associe from the Université de Grenoble, France, 1991-95. In 1990, he received the F.N. Frenkiel Award from the Division of Fluid Mechanics of the American Physical Society in recognition for his work on turbulent, two-phase flows.

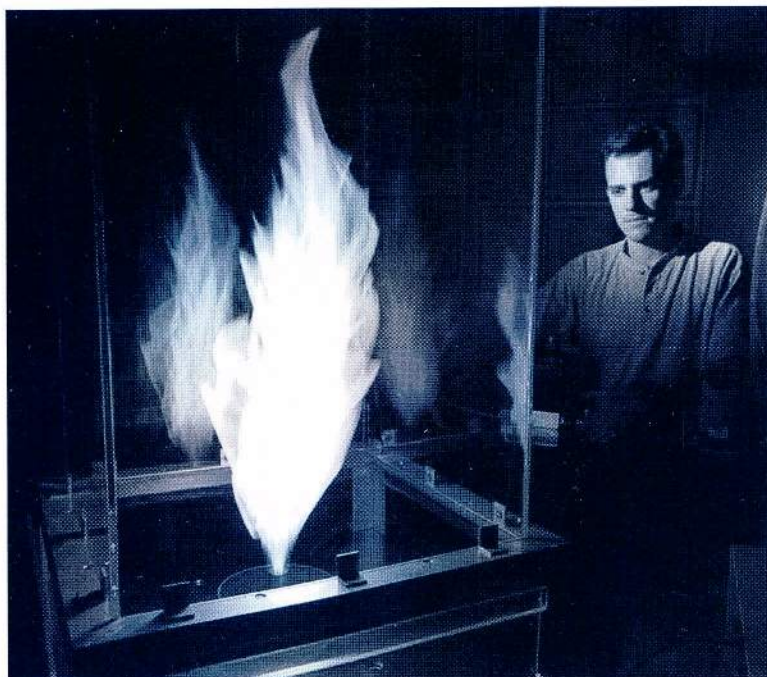
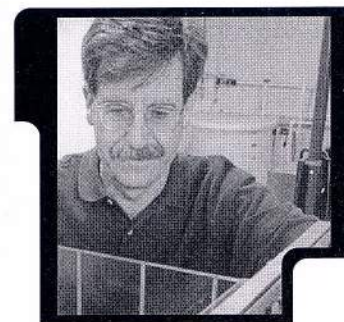

Dr. Christophe Clanet conducting an experiment on a turbulent diffusion flame subjected to simultaneous axial and azimuthal forcing.

### Recent Representative Publications

1. J.C. Lasheras, A. Liñán, A. Lecuona and P. Rodriguez, "Vorticity Dynamics in Three-dimensional Pulsating Jet Diffusion Flames," *24th Symposium (International) on Combustion*, pp. 679-691, The Combustion Institute, Pittsburgh, PA, 1993.
2. A. Ganan-Calvo, J.C. Lasheras, J. Davila and A. Barrero, "The Electrostatic Spray Emitted from an Electrified Conical Meniscus," *Journal of Aerosol Sciences*, Vol. 25, pp. 1121-1142, 1994.
3. D. Schowalter, C.W. Van Atta and J.C. Lasheras, "A Study of Streamwise Vortex Structure in a Stratified Shear Layer," *Journal of Fluid Mechanics*, Vol. 281, pp. 247-291, 1994.
4. K. Kiger and J.C. Lasheras, "Effect of Vortex Pairing on Particle Dispersion and Kinetic Energy Transfer in a Two-phase Turbulent Free Shear Layer," *Journal of Fluid Mechanics*, Vol. 302, pp. 149-178, 1995.

## SHUI-CHI LI

PhD in Mechanical and Aerospace Engineering  
Assistant Research Scientist



Dr. Li joined the CECR scientific staff after receiving his PhD from Princeton University in 1990. Prior to that, he received his MS degree from Beijing University of Aeronautics and Astronautics in 1980 and performed research there on solid-propellant rockets. He has been working on various research topics such as solid-propellant and liquid-propellant combustion, turbulent reacting flows, spray dynamics and combustion, soot formation and oxidation,

combustion synthesis and metal particle combustion. Currently he is in charge of experimental research in the CECR combustion laboratory and conducts experiments on two-phase reacting flows,  $\text{NO}_x$  reduction in hydrocarbon flames and synthesis of nanoparticles in silane/ammonia combustion by using a phase-Doppler particle analyzer, laser-Doppler velocimetry, gas chromatography and other experimental techniques.

### Representative Recent Publications

1. S.C. Li, F.A. Williams and S.B. Margolis, "Effects of Two-Phase Flow in a Model for Nitramine Deflagration," *Combustion and Flame*, Vol. 80, pp. 329-349, 1990.
2. S.C. Li, "Optical Measurement of Size Histories of Boron Particles in Ignition and Combustion Stages," *Combustion Science and Technology*, Vol. 77, pp. 149-169, 1991.
3. S.C. Li, P.A. Libby and F.A. Williams, "Spray Impingement on a Hot Surface in Reacting Stagnation Flows," *AIAA Journal*, Vol. 33, pp. 1046-1055, 1995.
4. S.C. Li, N. Ilincic and F.A. Williams, "Reduction of  $\text{NO}_x$  Formation by Water Sprays in Strained Two-Stage Flames," *Journal of Engineering for Gas Turbines and Power*, in press, 1996.

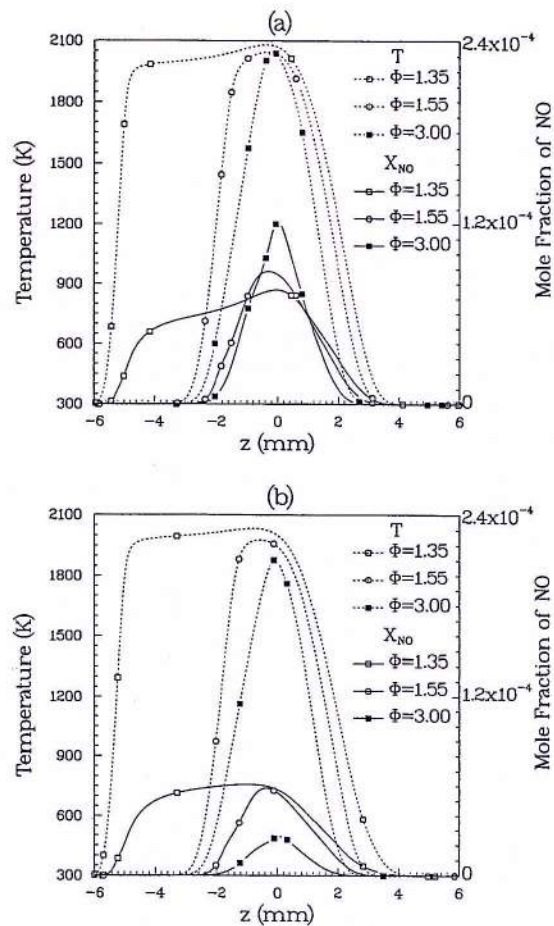

Predicted profiles of temperature and  $\text{NO}$  concentration in two-stage methane-air flames at different equivalence ratios  $\Phi$ : (a) without water; (b) with 10% water added in the air stream.

## PAUL A. LIBBY

PhD in Applied Mechanics

Professor Emeritus of Fluid Mechanics

Professor Libby received his PhD from the Polytechnic Institute of Brooklyn in 1949 and has been engaged in teaching and research since then, first at the Polytechnic and, since 1964, at UCSD. His research has always been connected with the broad area of fluid dynamics. At

present, he works in combustion theory, turbulence and turbulent combustion. Among his professional distinctions are his election as fellow in AIAA and APS and award of a Guggenheim Fellowship in 1972-73 and of a Royal Society Guest Research Fellowship, 1982.

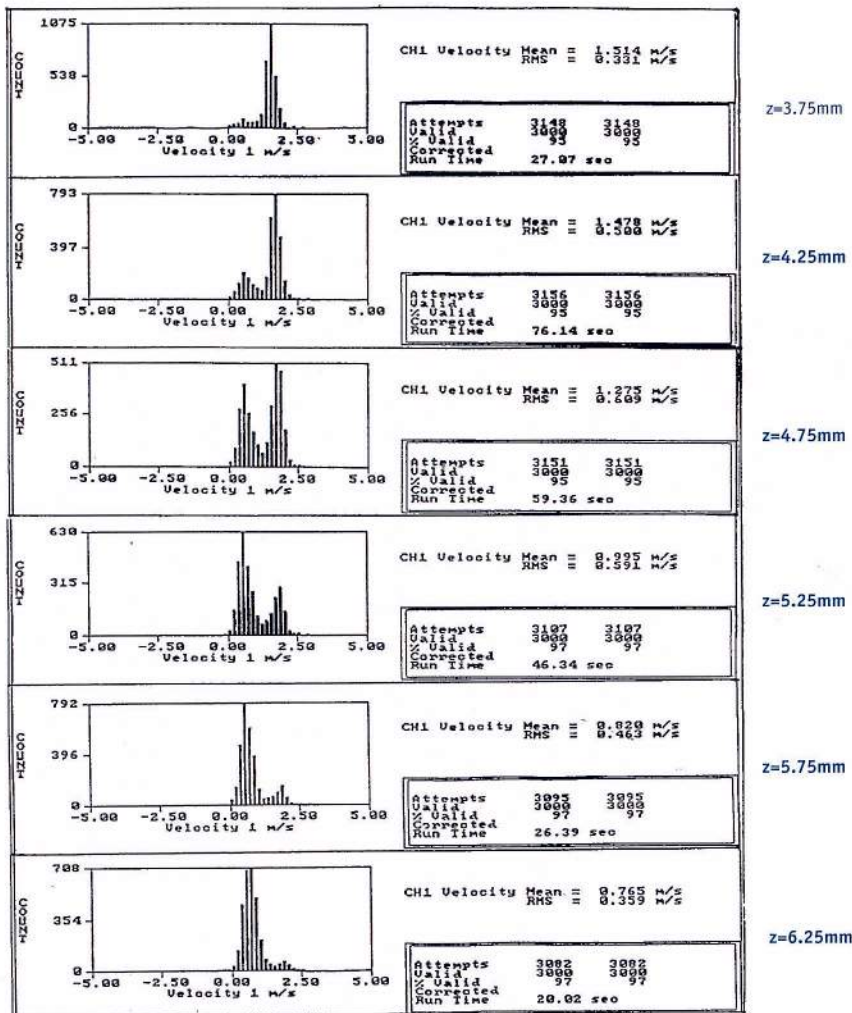
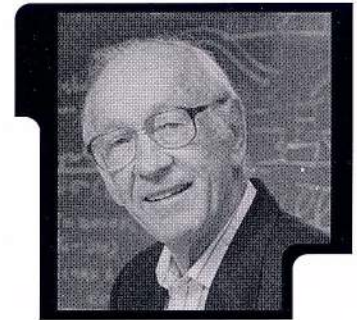

Axial velocity data histogram measured around turbulent premixed flame by the two-component PDPA ( $z=0$ —stagnation point;  $z=31$ mm the exit plane of the mixture of air and methane).

### Recent Representative Publications

1. K.N.C. Bray, M. Champion and P.A. Libby, "Premixed Flames in Stagnating Turbulence. Part III - The  $k-\epsilon$  Theory for Reactants Impinging on a Wall," *Combustion and Flame*, Vol. 91, pp. 165-186, 1992.
2. M. Champion and P.A. Libby, "Reynolds Stress Description of Opposed and Impinging Turbulent Jets. Part I. Opposed Jets," *Physics of Fluids*, Vol. 5, pp. 203-216, 1993.
3. M. Champion and P.A. Libby, "Reynolds Stress Description of Opposed and Impinging Turbulent Jets. Part II. Axisymmetric Jets Impinging on a Nearby Wall," *Physics of Fluids*, Vol. 6, pp. 1805-1819, 1994.
4. F.A. Maury and P.A. Libby, "Nonpremixed Flames in Stagnating Turbulence. Part I - the  $k-\epsilon$  Theory with Equilibrium Chemistry for the Methane-Air System," *Combustion and Flame*, Vol. 102, pp. 341-356, 1995.

## HURT O'FERRALL LUND

PhD in Engineering Science  
Assistant Research Scientist

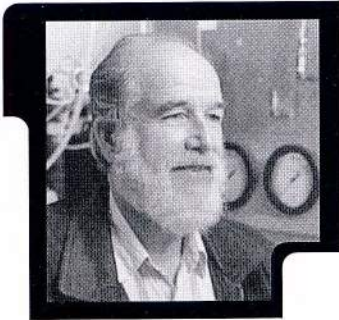

Dr. Lund, a research scientist in thermal science at UCSD's CECR, also provides technical consultancy to energy and process industries. After he received his BS and MS degrees in mechanical engineering from University of Manitoba and University of Michigan, Ann Arbor, respectively, he earned his PhD from UCSD in 1978. His technical experience includes twenty years of advanced heat transfer in industry and eight years of academic and teaching activities at San Diego State University and elsewhere. He is an active member of the American Society of Mechanical Engineers, having organized several technical conferences and sessions,

and is a registered professional engineer by the state of California. At UCSD, Dr. Lund's work involves energy conversion, with an emphasis in alternative technologies. His current research is focused on numerical modeling of thermal and chemical processes in fluidized beds using a recent computer program for computational fluid dynamics (CFD) and also includes such topics as space-based solar-thermal energy conversion, turbulent flow and heat transfer at a rotating cylinder and thermophotovoltaic energy conversion. In addition, he is studying heat-pipe and thermal radiation phenomena for spacecraft thermal management and thermal processes in quartz reactors for chemical vapor deposition.

### Recent Representative Publications

1. K.O. Lund, "Attenuation Thermal Energy Storage in Sensible-Heat Solar-Dynamic Receivers," *Space Power Journal*, Vol. 13, pp. 39-60, 1994.
2. K.O. Lund, "Asymptotic Analysis of Turbulent Flow for a Rotating Cylinder," *Symposium on Asymptotic Methods for Turbulent Shear Flows at High Reynolds Numbers*, Ruhr-Universität, Bochum, Germany, 1995.
3. K.O. Lund, G. Henschke and T.R. Knowles, "Analysis of Close-Packed Brush-Fiber Thermal Interfaces for Space-Based Thermal Management," *Journal of Spacecraft and Rockets*, Vol. 32, pp. 845-849, 1995.
4. K.O. Lund, "A Direct-Heating Energy-Storage Receiver for Dish/Stirling Solar Energy Systems," *Journal of Solar Energy Engineering*, Vol. 118, pp. 001-005, 1996.

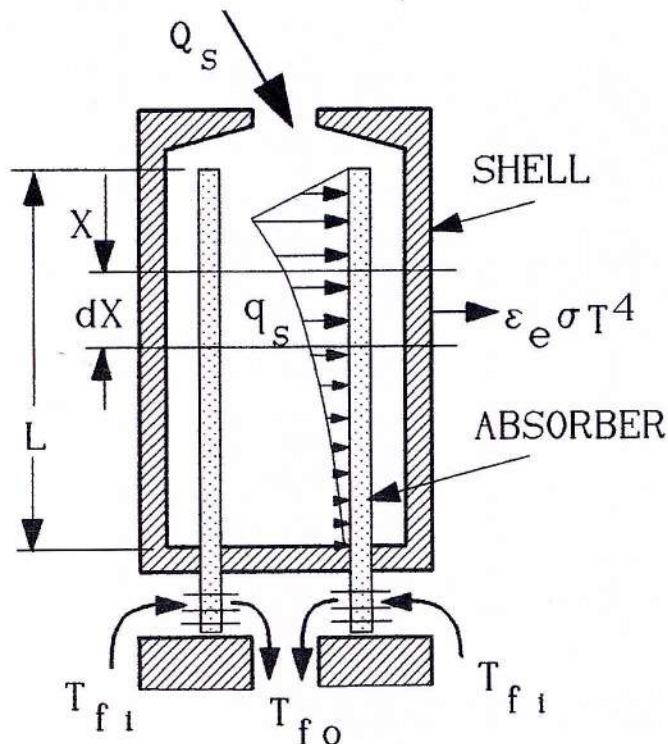

Attenuation receiver concept.

## MARC A. MEYERS

PhD in Physical Metallurgy  
Professor of Materials Science

Professor Meyers received his PhD from the University of Denver in 1974 and after holding a variety of teaching and research positions, joined the UCSD faculty in 1988. He specializes in use of combustion reactions to synthesize novel materials. Monolithic ceramics (TiC, TiB<sub>2</sub>), composites (TiC-Al<sub>2</sub>O<sub>3</sub>, TiB<sub>2</sub>-SiC) and cermets (TiC-Ni, TiC-NiTi) are produced in his laboratory through exothermic chemical reactions. The reaction is carried out in special experimental configurations in which densification can take place. A new method

of densification using a high-speed forging machine has been developed and successfully applied to these materials by Professor Meyers, who is also investigating the mechanisms of shock-induced and shear-induced chemical reactions. Exothermic chemical reactions are also triggered by the propagation of shock waves through reactive powder mixtures. Energy is localized where deformation occurs. The control of reaction rates in dynamic deformation is important and can provide prescribed energy release rates in energetic materials.

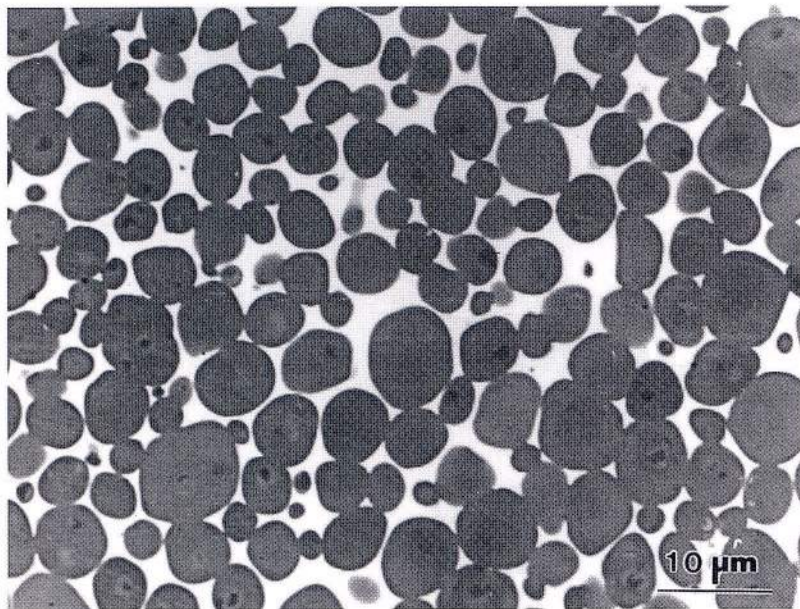
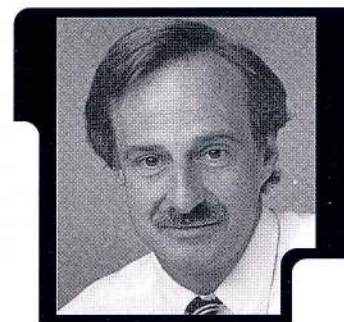

TiC-Ni cermet produced by combustion synthesis and dynamic deformation. This cermet has superior mechanical properties.

### Recent Representative Publications

1. J.C. LaSalvia, M.A. Meyers and D.K. Kim, "Combustion Synthesis/Dynamic Densification of TiC-Ni Cermets," *Journal of Materials Synthesis and Processing*, Vol. 2, pp. 255-274, 1994.
2. J.C. LaSalvia, D.K. Kim, R.A. Lipsett and M.A. Meyers, "Combustion Synthesis in the Ti-C-Ni-Mo System: I. Macrokinetics and Micromechanisms," *Metallurgical and Materials Transactions*, Vol. 26A, pp. 3001-3010, 1995.
3. J.C. LaSalvia and M.A. Meyers, "Combustion Synthesis in the Ti-C-Ni-Mo System: II. Analysis," *Metallurgical and Materials Transactions*, Vol. 26A, pp. 3011-3019, 1995.
4. M.A. Meyers, S.S. Batsanov, S.M. Gavrilkin, H.C. Chen, J.C. LaSalvia and F.D.S. Marquis, "Effect of Shock Pressure and Plastic Strain on Chemical Reactions in Nb-Si and Mo-Si Systems," *Materials Science and Engineering*, Vol. A201, pp. 150-158, 1995.



## DAVID R. MILLER

PhD in Chemical Engineering  
Professor of Chemical Engineering

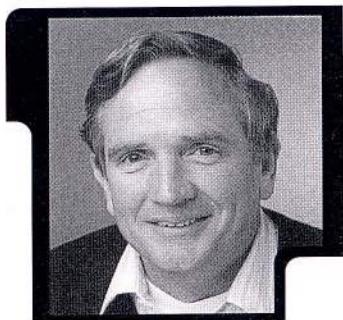

Professor Miller's research interests are primarily in interface chemistry and physics, with applications to film growth and surface characterization, as well as gas kinetics and dynamics. He has developed several molecular beam facilities in which beams of atoms or clusters of atoms can be formed and characterized before interacting with a variety of substrates. These particles can stick to the surfaces and subsequently grow new thin layered materials or scatter from the surface such that the dynamics of the interaction can be studied. His students have studied metal beams and ceramic beams as well as inert helium-atom scattering. After growing films, examinations are made of their chemical and physical properties, of interest in catalysis and magnetic devices, and of their optical properties, such as reflectivity and laser-induced dam-

age. A new area of interest is the cause and effect of mechanical damage, e.g., friction wear, at the interface between well-characterized materials. The formation of cluster beams is also a research interest and involves studies of chemistry coupled to gas dynamics in rapid gas expansions. The expansions are probed spectroscopically, and the equations of motion, coupled to the kinetics, are solved in order to understand and predict the beam properties. In another new area, the oxidation of hydrocarbons in supercritical water is studied by using a quartz micro-reactor as a molecular-beam source coupled to a mass spectrometer through a free jet expansion. In addition to ultrahigh vacuum techniques, diagnostics include mass spectrometry, infrared spectroscopy, Auger and ESCA electron spectroscopies, induction magnetometry, LEED, SEM and TEM.

### Recent Representative Publications

1. J.I. Brand and D.R. Miller, "Ceramic Beams and Thin Film Growth," *Thin Solid Films*, Vol. 166, pp. 139-148, 1988.
2. G. Tepper and D.R. Miller, "Coherent Scattering of the Hydrogen Dimer from a LiF Crystal," *Journal of Chemical Physics*, Vol. 98, pp. 9585-9594, 1993.
3. A. Zwan and D.R. Miller, "Laser Induced Damage Threshold Measurements at the Microscopic Level," *Materials Research Society*, Vol. 285, pp. 243-248, 1993.
4. B. Andrien and D.R. Miller, "A Comparison of Magnetic Properties of Thin Films of Fe/GaAs (100) and Ni/Mica," *Materials Research Society*, Vol. 280, pp. 505-508, 1993.

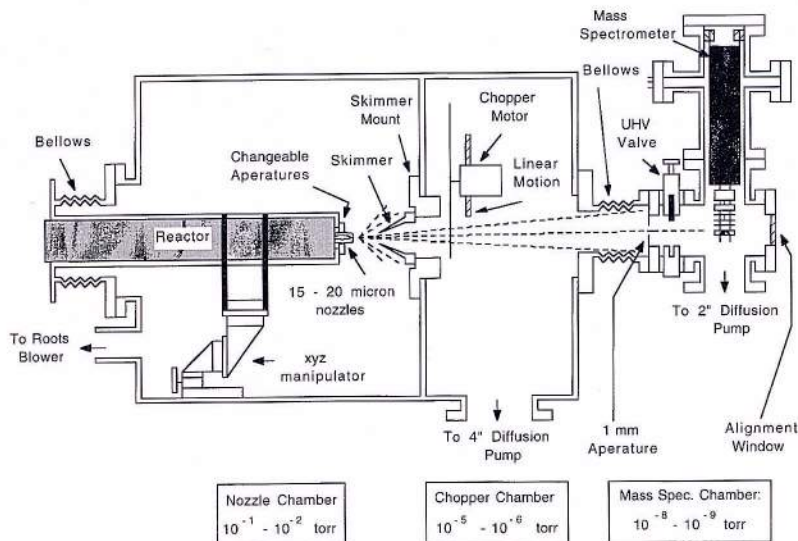

Supercritical water micro-reactor coupled to mass spectrometer sampling system.

## VITALI F. NESTERENKO

PhD in Physics

Associate Professor of Materials Science

Professor Nesterenko received his PhD and doctor of sciences degree from the Russian Academy of Sciences in 1975 and 1989, respectively. He held positions as the Head of the Research Department in the Special Design Office of High-Rate Hydrodynamics and the Head of the Laboratory of the Advanced Materials in Lavrentyev Institute of Hydrodynamics. He joined UCSD in 1994 and became a faculty member in 1996. Areas of his scientific interest include nonlinear wave phenomena in granular media, micromechanics of porous and granular materials, materials fabrication by dynamic methods, shear localization phenomena and chemical reactions under high-strain-rate deformation in heterogeneous materials. Recently he developed a new method (Thick-Walled Cylinder Method) to investigate shear assisted chemical reactions

in solid reactive powder mixtures and successfully applied it to Nb-Si and Ti-Si systems. This method creates controlled, high-strain-rate deformation with overall strain  $\sim 1$  (strain rate  $\sim 10^4 \text{ s}^{-1}$ ) and with local shear strain inside shear bands  $\sim 10 - 100$  (strain rate  $\sim 10^7 \text{ s}^{-1}$ ). It was demonstrated that high-strain-rate plastic deformation of porous mixtures results in an array of shear bands which can trigger reaction in the volume. The precisely tuned global and localized strain can be produced for different reactant mixtures, that are especially important in the vicinity of chemical reaction threshold. Currently he is developing the Laboratory of Mechanical Processing of Advanced Materials and one of the research directions will be the optimized HIP (Hot Isostatic Pressing) of ceramic composites after exothermic chemical reaction.



Array of shear bands below the global deformation threshold for overall chemical reactions, and above the threshold for uniform deformation, global strain  $\sim 0.31$ .

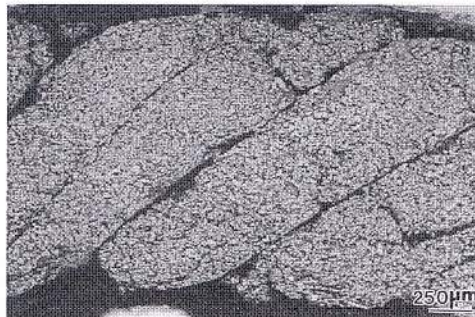

Completely reacted material (Ti - Si) as the result of shear localization (kink on the interface with copper tube) above the threshold for overall chemical reactions. Small unreacted islands adjacent to the copper tube are shown by arrows.

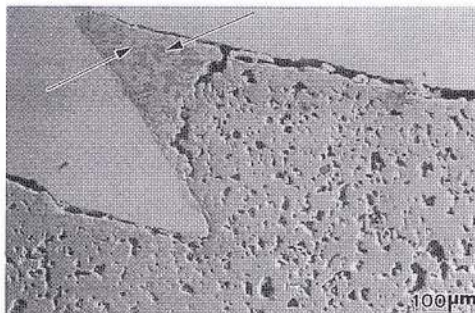

### Recent Representative Publications

1. V. F. Nesterenko, M.A. Meyers, H.C. Chen and J.C. LaSalvia, "Controlled High-Rate Localized Shear in Porous Reactive Media," *Applied Physics Letters*, Vol. 65, pp. 3069-3071, 1994.
2. V. F. Nesterenko, M.A. Meyers, H.C. Chen and J.C. LaSalvia, "The Structure of Controlled Shear Bands in Dynamically Deformed Reactive Mixtures," *Metallurgical and Materials Transactions*, Vol. 26A, pp. 2511-2519, 1995.
3. V. F. Nesterenko, "Dynamic Loading of Porous Materials: Potential and Restrictions for Novel Materials Applications," *Metallurgical and Materials Applications of Shock-Wave and High-Strain-Rate Phenomena*, (L.E. Murr, K.P. Staudhammer and M.A. Meyers, editors), Elsevier Science, pp. 3-13, 1995.
4. V. F. Nesterenko, M.A. Meyers, H.C. Chen and J.C. LaSalvia, "Chemical Reactions in Controlled High-Strain-Rate Shear Bands," *Proceedings of American Physical Society Topical Group on Shock Compression of Condensed Matter Conference*, AIP, 1996.

## HEIHO NOMURA

PhD in Mechanical Engineering  
Assistant Professor, Mechanical Engineering



Keiko K. Nomura received her PhD from the Department of Mechanical and Aerospace Engineering at University of California, Irvine in 1994 and immediately joined the faculty at UCSD. Prior to her doctorate work, she held a development engineer position with Battelle Pacific Northwest Laboratories from 1983-87. Her primary research interests are in the areas of turbulence, combustion and computational fluid dynamics. Other areas are

multiphase flows, heat and mass transfer. Current research activities include studies of the structure and dynamics of small-scale turbulence and direct numerical simulations of turbulent combustion. Dr. Nomura is a member of the Combustion Institute, the American Physical Society (APS), the American Institute of Aeronautics and Astronautics (AIAA) and the American Society of Mechanical Engineers (ASME).

### Recent Representative Publications

1. K.K. Nomura and P.V. Farrell, "Heat and Mass Transfer Coefficients for Porous Horizontal Cylinders," *AIChE Journal*, Vol. 31, pp. 1217-1219, 1985.
2. S.E. Elghobashi and K.K. Nomura, "Direct Simulation of a Passive Diffusion Flame in Sheared and Unsheared Homogenous Turbulence," *Turbulent Shear Flows 7*, W.C. Reynolds Ed. (Springer-Verlag), pp. 313-329, 1990.
3. K.K. Nomura and S.E. Elghobashi, "Mixing Characteristics of an Inhomogeneous Scalar in Isotropic and Homogeneous Sheared Turbulence," *Physics of Fluids A*, Vol. 4, pp. 606-625, 1992.
4. K.K. Nomura and S.E. Elghobashi, "The Structure of Inhomogeneous Turbulence in Variable Density Nonpremixed Flames," *Theoretical and Computational Fluid Dynamics*, Vol. 5, pp. 153-175, 1993.

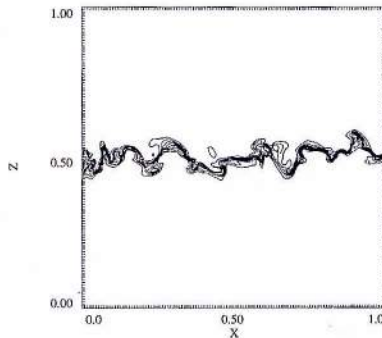

a.

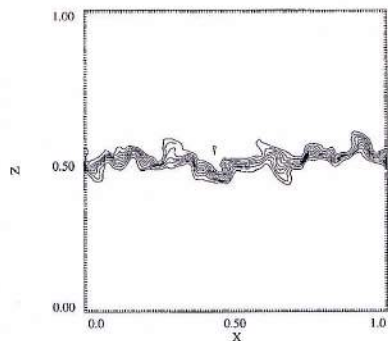

b.

Direct numerical simulation of turbulent nonpremixed flames. Shown: Instantaneous isoscalar contours of mixture fraction for a. no heat release, b. with heat release.

## STANFORD S. PENNER

PhD in Physical Chemistry

Professor Emeritus of Engineering Physics

Professor Penner received his PhD from the University of Wisconsin in 1946. Before coming to UCSD in 1964 as founding chair of the Department of AMES, he served as professor of jet propulsion at the California Institute of Technology. At UCSD, he has held the positions of vice chancellor for academic affairs, director of the Institute for Pure and Applied Physical Sciences, and director of CECR. He served as founding editor of the *Journal of Quantitative Spectroscopy and Radiative Transfer* (1960-92) and *Energy—The International Journal* (since 1975). His current research interests

include energy technologies, environmental issues, management and policies. Among Professor Penner's professional distinctions are membership in the National Academy of Engineering, and in the International Academy of Astronautics, election as Fellow of the American Academy of Arts and Sciences, and election to seven other learned societies, numerous national and international awards and honorary degrees, a Distinguished Associate Award from the U.S. Department of Energy and memberships on the Board of Directors of several industrial concerns.

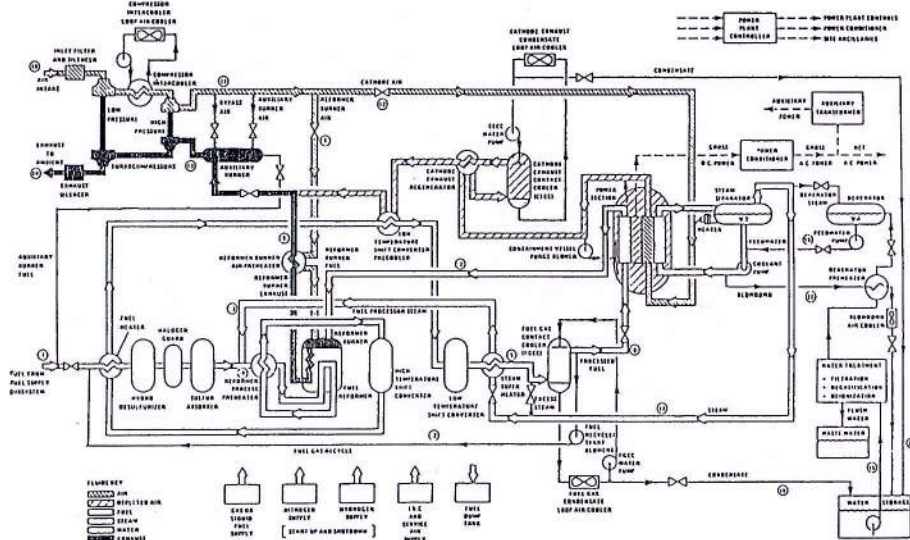

Process-flow schematic for the 11-megawatt phosphoric acid-fuel cell powerplant at the Tokyo Electric Power Company; from Ref. 4.

### Recent Representative Publications

1. S.S. Penner, C.P. Li, M.B. Richards and D.F. Wiesenhahn, "A Model for De Novo Synthesis and Decomposition Rates of Dioxins and Furans in Municipal-Waste Incinerators," *The Science of the Total Environment*, Vol. 104, pp. 35-46, 1991.
2. S.S. Penner, J. Haraden and S. Mates, "Long-Term Global Energy Supplies with Acceptable and Environmental Impacts," *Energy—The International Journal*, Vol. 17, pp. 883-899, 1992.
3. S.S. Penner, "A Low-Cost/No Regrets View of Greenhouse Gas Emissions (GHGE) and Global Warming (GW)," *Journal of Clean Technology and Environmental Sciences*, Vol. 3, pp. 255-259, 1993.
4. S.S. Penner, et al, "Commercialization of Fuel Cells," *Energy—The International Journal*, Vol. 20, pp. 331-470, 1995.

## SUTANU SARKAR

PhD in Mechanical and Aerospace Engineering  
Associate Professor of Mechanical Engineering



### Recent Representative Publications

1. S. Sarkar, "The Stabilizing Effect of Compressibility in Turbulent Shear Flow," *Journal of Fluid Mechanics*, Vol. 282, pp. 163-186, 1995.
2. G. Balakrishnan, S. Sarkar and F.A. Williams, "Direct Numerical Simulation of Diffusion Flames with Large Heat Release in Compressible Homogeneous Turbulence," *31st AIAA/ASME/SAE/ASEE Joint Propulsion Conference*, San Diego, 1995.
3. S. Sarkar, G. Erlebacher, M.Y. Hussaini and H.O. Kreiss, "The Analysis and Modelling of Dilatational Terms in Compressible Turbulence," *Journal of Fluid Mechanics*, Vol. 227, pp. 473-493, 1991.
4. C. G. Speziale, S. Sarkar and T.B. Gatski, "Modeling the Pressure-Strain Correlation of Turbulence: an Invariant Dynamical Systems Approach," *Journal of Fluid Mechanics*, Vol. 227, pp. 245-272, 1991.

Professor Sarkar received a B. Tech in mechanical engineering from IIT, Bombay, in 1982 and a PhD in mechanical and aerospace engineering from Cornell University in 1988. Subsequently, he was at ICASE, NASA Langley Research Center as a staff scientist until 1993 when he joined UCSD as an assistant professor. He has been an associate professor in the AMES department at UCSD since 1995. Professor Sarkar's research is in the general area of computational and theoretical fluid mechanics with specialization in the simulation, modeling and control of turbulent flows in propulsion and the environment. Current topics of research include high-speed mixing layers and jets with and without reaction, modeling of compressibility and heat release effects in turbulence closures, large eddy simulation, mixing in shear flows with stable stratification and

sound generation by turbulent flows. The numerical simulations are performed in a state-of-the-art computing environment that includes high-end, local workstations as well as access to the latest supercomputers and visualization facilities in the San Diego Supercomputer Center. Professor Sarkar has edited the book *Studies in Turbulence*, been an editor for a special issue of the journal, *Theoretical and Computational Fluid Dynamics*, and has over thirty journal and conference publications. His research has been recognized by a NASA achievement award, appointment as an AGARD consultant to ONERA, and invitations to lecture at international meetings. Professor Sarkar is a member of the American Physical Society (APS), the American Institute of Aeronautics and Astronautics (AIAA) and the American Society of Mechanical Engineers (ASME).

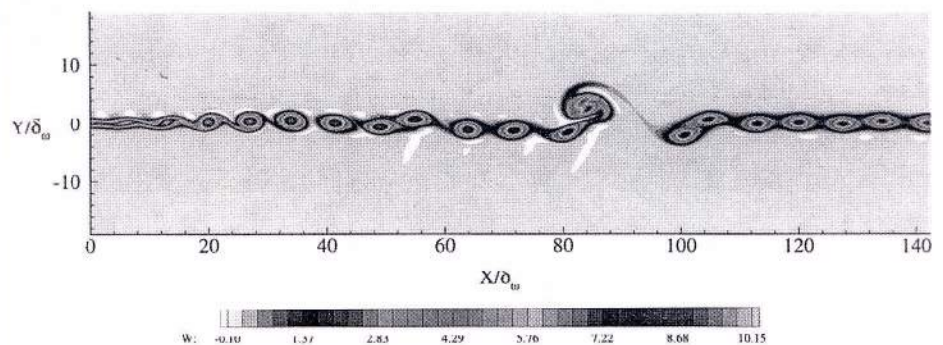

Direct numerical simulation of a spatially evolving shear layer at the edge of a jet. The rollup and pairing of vortices is clearly seen.

## K. SESHADRI

PhD in Engineering Science

Professor of Chemical Engineering and Fluid Mechanics and Associate Director, CECR

Professor Seshadri received his BE degree from Coimbatore Institute of Technology (India) in 1970, his MS degree from the State University of New York at Stony Brook in 1973, and his PhD degree from the University of California, San Diego in 1977. After completing his PhD he was a postdoctoral research staff member at Yale University, member of the technical staff at TRW, and assistant professor of mechanical engineering at the University of Southern California. He joined the UCSD faculty in 1982. Professor Seshadri's field of specialization is combustion. Current research interests include studies of mechanism of combustion of hydrocarbons and alcohols, chemical

inhibition of flames, mechanisms of combustion of double base and nitramine propellants, mechanisms of formation of soot and carcinogenic compounds such as benzene in flames and asymptotic analysis describing laminar combustion processes through reduced chemical kinetics. A number of his studies are performed in collaboration with scientists at RWTH Aachen and Army Research Laboratory at Aberdeen Proving Ground, Maryland. Among his honors and professional distinctions are his invitation to present a keynote paper on asymptotic analysis of flame structure at the 26th Symposium (International) on Combustion.

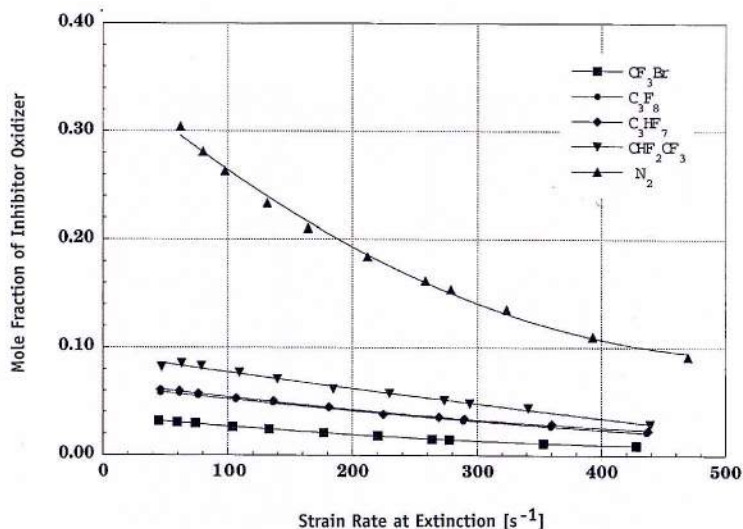

Mole fraction of various agents as a function of the strain rate at extinction. The fuel tested is heptane.

### Recent Representative Publications

1. K. Seshadri, N. Peters and F.A. Williams, "Asymptotic Analysis of Stoichiometric and Lean Hydrogen-Air Flames," *Combustion and Flame*, Vol. 96, pp. 407-427, 1993.
2. K. Seshadri, and F.A. Williams, "Reduced Chemical Systems and their Applications in Turbulent Combustion," Chapter four in *Turbulent Reactive Flows* (Eds. P.A. Libby and F.A. Williams), Academic Press, New York, pp. 153-210, 1994.
3. K. Seshadri and N. Ilinic, "The Asymptotic Structure of Inhibited Nonpremixed Methane-Air Flames," *Combustion and Flame*, Vol. 101, pp. 271-294, 1995.
4. D. Trees, K. Seshadri and A. Hamins, "Experimental Studies of Diffusion Flame Extinction with Halogenated Fire Suppressants," Chapter 17 in *Halogen Replacements: Technology and Science* (A.W. Miziolek and W. Tsang, Eds.) ACS Symposium Series 611, American Chemical Society, Washington, D.C., pp. 190-203, 1995.

## MASSOUD SIMNAD

PhD in Materials Science and Engineering

Adjunct Professor of Materials Science and Engineering, Nuclear Engineering and Energy Technologies

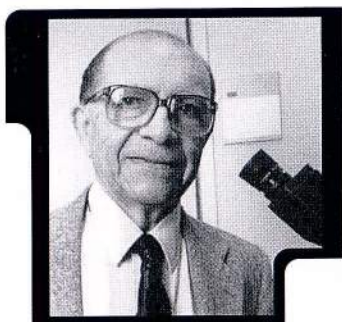

### Recent Representative Publications

1. E.A. Early, M.T. Simnad and M.B. Maple, "Properties of Alloy Precursors and Resulting Superconducting YBaCuOAg Composite," *Journal of Applied Physics*, Vol. 71, pp. 1327-1334, 1992.
2. A.J. Strutt, M.T. Simnad, XX Lavernia and K.S. Vecchio, "Analytical Electron Microscopy of AgYBaCu Superconductor Precursor Material," *Proceedings from the 51st Annual Meeting of the Microscopy Society of America*, p. 1192, 1993.
3. M. Chae, M.B. Maple, M.T. Simnad, S. Anders, A. Anders and I.G. Brown, "Preparation of Cathodic Arc Deposited HTSC, Bi<sub>2</sub>Sr<sub>2</sub>CaCu<sub>2</sub>O<sub>8+y</sub>-Ag Composite Thin Films on Ag Substrates," published in *IEEE Journal of Superconductivity*, 1995.
4. M.T. Simnad, "Materials in the Radiation Environment of Fusion Reactors," *UCSD, IMM Report No. 93-41*, pp. 2-12, January, 1994.

Professor Simnad received his BSE from Imperial College of Science and Technology, London University, in 1942 and his PhD in materials science from Cambridge University in 1946. He was a postdoctoral research fellow at Cambridge University for three years. In 1949 he was awarded the Weston Postgraduate Fellowship of the Electrochemical Society and was Guest Fellow and faculty member at Carnegie-Mellon University (1950-56) a visiting professor at MIT (1962-63) and held senior positions at General Atomics in San Diego (1956-81). He has been adjunct professor and consultant at the University of California, San Diego since 1981, and a member of the *Center for Energy and Combustion Research* (teaching courses in Materials Science and Engineering, Nuclear Fission and Fusion Energy, and Energy Technologies). His research and consulting activities include materials sci-

ence and engineering studies related to advanced nuclear fission and fusion materials and high temperature superconducting materials. He is the author of three monographs, editor of two monographs, author or coauthor of over 120 papers in scientific and technical journals, and holds eighteen patents (including nuclear reactor fuels). Professor Simnad is a fellow of four societies (American Association for the Advancement of Science, American Society for Metals, American Nuclear Society, Materials Research Society) and member of the Electrochemical Society, American Institute of Aeronautics & Astronautics and Sigma Xi. He is an associate editor of *Energy—The International Journal*. In 1993, he received an Outstanding Achievement Award from the American Nuclear Society. In 1995, he was elected a member of the National Academy of Engineering.

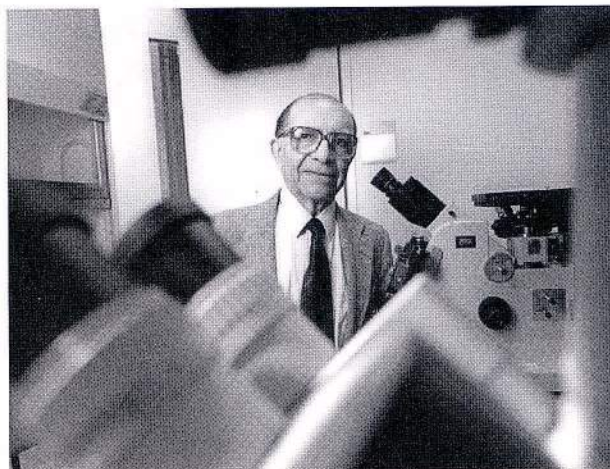

Laboratory equipment close-up.

## FORMAN A. WILLIAMS

PhD in Engineering Science

Professor of Engineering Physics and Combustion and Director, CECR

Professor Williams received his BSE from Princeton University in 1955 and his PhD from California Institute of Technology in 1958. He then taught at Harvard University until 1964, at which time he joined the UCSD faculty. In January 1981, Professor Williams accepted the Robert H. Goddard Chair in the Department of Mechanical and Aerospace Engineering at Princeton University, where he remained until 1988, when he returned to UCSD to assume his present position. His field of specialization is combustion, and he is author of *Combustion Theory* (Addison, Wesley, 2nd ed., 1985) and co-author of *Fundamental Aspects of Combustion* (Oxford, 1993). He is a deputy editor of *Combustion and Flame* and a member of the editorial advisory boards of *Combustion Science and Technology*, *Progress in Energy and Combustion Science* and *Archivum Combustionis*. Current research interests of Professor Williams include studies of mechanisms of

generation of oxides of nitrogen in flames, the dynamics and combustion of fuel sprays, combustion instabilities in liquid-propellant rocket motors, phenomena of combustion at reduced gravity, high-speed turbulent combustion in air-breathing engines and asymptotic analyses describing laminar combustion processes through reduced chemical kinetics. Among the professional distinctions of Professor Williams are memberships in the National Academy of Engineering and in the National Academy of Engineering of Mexico, election as fellow in the American Institute of Aeronautics and Astronautics (AIAA), receipt of an Alexander von Humboldt U.S. Senior Scientist Award from Germany, selection to a lectureship at the Instituto de España in Madrid, receipt of the Silver and Bernard Lewis Gold Medals of the Combustion Institute, and receipt of the AIAA Pendray Aerospace Literature Award.



Studying the outcome of a spray-combustion experiment.

### Recent Representative Publications

1. S.B. Margolis and F.A. Williams, "Effects of Two-Phase Flow on the Deflagration of Porous Energetic Materials," *Journal of Propulsion and Power*, Vol. 11, pp. 759-768, 1995.
2. H. Ikeda, J. Sato and F.A. Williams, "Surface Kinetics for Catalytic Combustion of Hydrogen-Air Mixtures on Platinum at Atmospheric Pressure in Stagnation Flows," *Surface Science*, Vol. 326, pp. 11-26, 1995.
3. M.L. Rightley and F.A. Williams, "Analytical Approximations for Structures of Wet CO Flames with One-Step Reduced Chemistry," *Combustion and Flame*, Vol. 101, pp. 287-301, 1995.
4. A. Liñán and F.A. Williams, "Autoignition of Nonuniform Mixtures in Chambers of Variable Volume," *Combustion Science and Technology*, Vol. 105, pp. 245-263, 1995.



## Living in San Diego

UCSD is situated on the bluffs overlooking the Pacific Ocean in La Jolla. The climate is mild throughout the year, encouraging most San Diegans to live an out-of-doors lifestyle. This seaside community remains a favorite vacation colony for people of all ages. La Jolla has some of the finest beaches and coves, restaurants, art galleries and other recreational and cultural attractions in the nation.

Naturally, then, much of the social life at UCSD centers around outdoor activities. Miles of running, walking and bike paths extend from the small-town atmosphere of the North County coast, south to the primitive wilderness of the Baja California Peninsula in Mexico. Waterfront activities include surfing, SCUBA diving and water skiing with beach parties abundant throughout the year.

San Diego offers a variety of recreational opportunities, including Old Town (where California was born), Sea World in Mission Bay, the world-famed San Diego Zoo, as well as the Sports Arena and San Diego Jack Murphy Stadium, sites of a year-round calendar of major league sporting events and concerts.

Theatre-goers will be impressed by San Diego's wide variety of stage presentations. Students need not venture off-campus for theatrical and cultural entertainment. The renowned La Jolla Playhouse, birthplace of the Tony-Award winning *Tommy* and other successes, is located on the south end of campus. Additionally, UCSD's Department of

Theatre presents plays throughout the school year. Concerts ranging from rock to jazz to classics, performed by prominent musicians, are scheduled regularly.

In San Diego's famous Balboa Park, a short drive from campus, Starlight Musical Theatre presents Broadway entertainment in an open-air setting, under the stars. Also located in Balboa Park is the Old Globe, home of the National Shakespeare Festival and the Cassius Carter Center Stage, for a variety of eclectic theatrical entertainment. The Civic Theater, located in downtown San Diego, also schedules a full season of cultural events including opera, ballet and the San Diego Symphony.

The \$20 million Price Center, completed in 1989, provides a theatre, many meeting rooms and restaurants, as well as other recreational facilities for students. The Mandeville Center, a \$53 million fine arts building, houses offices, classrooms, and work spaces for the Departments of Music and Visual Arts, as well as an 850-seat auditorium. The three-level structure provides a center for art exhibits, concerts, and other cultural events.



### ***Mountains, Deserts and Beaches***

The San Diego metropolitan area—which includes UCSD—has the most favorable year-round climate in the United States. Fishing opportunities are plentiful offshore in kelp beds west of La Jolla and surrounding the Coronado Islands in the Mexican waters. Bass and trout fishing are found in nearby lakes and streams. An hour's drive east, the Laguna Mountains provide pleasure at all seasons, from summer sun to winter snow, for campers and hikers.

Beyond the Lagunas lies the vast Borrego Desert with its breathtaking display of wildflowers in the spring. Julian, a small mountain town famous for the annual apple festival, is a beautiful one-hour drive north-east of UCSD in the picturesque Cuyamaca Mountains.

For 900 miles southward from the U.S.-Mexican border stretches the Peninsula of Baja California, a mecca for lovers of unspoiled beaches and untouched mountains and deserts. The peninsula, site of the grueling Baja cross-country road races each year, is still largely unexplored wilderness.

